

CONDURA

OWNER'S
MANUAL



SMOKELESS
GRILLER



TABLE OF CONTENTS

Parts	01
General Safety Instructions	02
Operation	03
Cleaning Instructions	04
Maintenance	04
Product Specifications	05

PARTS

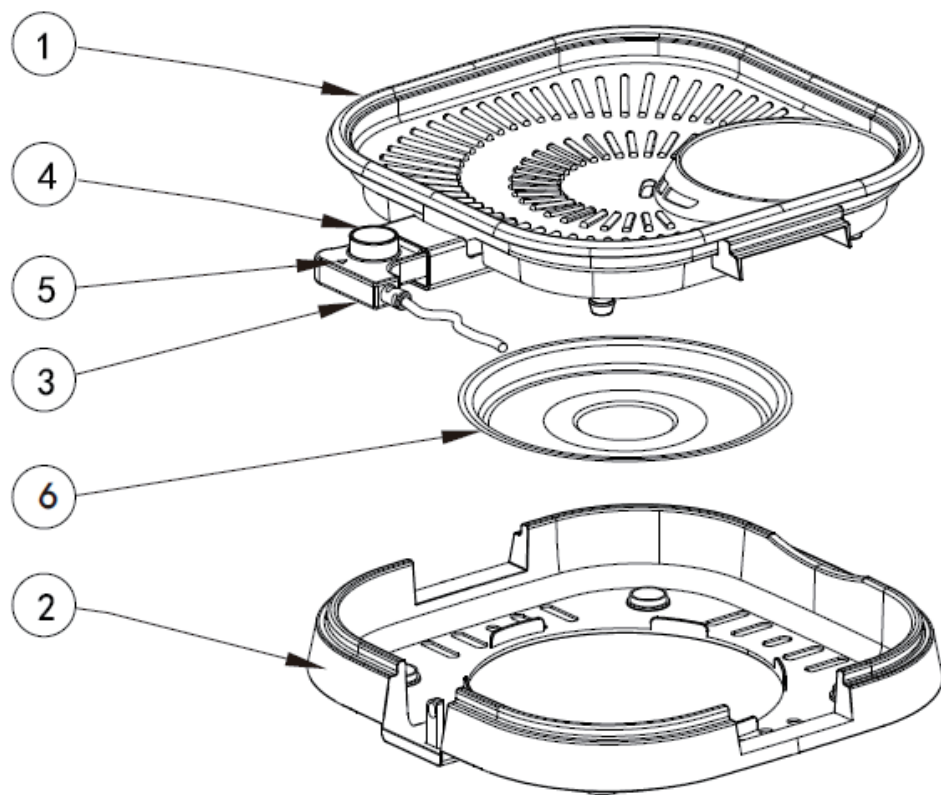

1. Heating Plate
2. Body
3. Controller
4. Thermostat Knob
5. Thermostat Indicator Light
6. Drip Tray

GENERAL SAFETY INSTRUCTIONS

Read the instructions carefully before operating the appliance. Keep this manual, the receipt and if possible, the box for storage.

- This appliance is designed for household use only. This appliance is not to be used commercially.
- Do not use outdoors.
- Keep the appliance away from heat sources, direct sunlight, liquid and sharp edges.
- Do not cover the appliance with aluminum foil to avoid overheating.
- Do not use the appliance with wet hands. If the appliance is moist/wet, unplug immediately.
- Use the appliance on a cool, flat surface.
- Do not put food straight to the heating element.
- Do not leave the appliance unattended when in use. Should you need to leave the area, please switch off the power.
- Regularly check the appliance for damage. If you see damage on the appliance or the power cord, discontinue use and contact Condura's customer service hotline.
- Do not repair the appliance yourself. To avoid hazards, contact Condura's customer service hotline for repair/replacement.
- To ensure your children's safety, please keep all packaging materials (plastic bags, boxes, polystyrene) out of their reach.
- To protect children from hazards posed by electrical appliances, make sure that the cable is away from their reach.
- Clean the appliance after every use.
- When cleaning or storing, always switch off the power, unplug, let it cool down and remove the accessories.
- Do not use abrasive objects when cleaning.
- Do not unplug by pulling on the power cord.
- This appliance is not to be used by persons (including children) with reduced physical, sensory or mental capabilities, or lack of experience and knowledge, unless they have been given supervision or instruction.
- This appliance is not intended to be operated by means of an external timer or separate remote-control system.
- Children should be supervised to ensure that they do not play with the appliance.
- Only the appropriate connector must be used for this appliances.

- This appliance is intended to be used in household and similar applications such as: Staff kitchen areas in shops, office and other working environments; farm houses; by clients in hotels, motels and other residential type environments; bed and breakfast type environments.
- Do not immerse any part of the appliance in water or other liquid.
- Do not use the appliance on any voltage except for 230V AC to avoid the risk of fire and electric shock. In case of power wire damage, do not use the appliance.
- During operation, do not move or shake the appliance.
- Warning: Avoid spillage on the connector.
- Warning: Misuse may cause potential injury.
- CAUTION: HOT SURFACE. Do not touch with bare hands. Always use the handles.

BEFORE USE

- Clean the appliance as recommended on "Cleaning Instructions".
- Heat up the grill for 10 minutes to eliminate fat residue and odor.
- Ensure that the room is well ventilated during use.

OPERATION

1. Prepare the griller by putting the heating plate and the body together and inserting the controller into the griller. Ensure that the thermostat knob is set to "0", and connect the power plug into the socket.
2. Turn the thermostat knob to your desired cooking temperature. Once the thermostat indicator light switches off, it means your griller has reached the set temperature.
3. Use only wooden or heat-resistant plastic spatula to avoid scratching the surface of the griller.
4. Place food evenly on the griller.
5. While cooking, it is normal for the thermostat indicator light to switch on and off. This means that the temperature you have set is being regulated.
6. After grilling, immediately unplug the griller and let it cool down.

TIPS

- Always defrost frozen food before grilling to ensure even cooking.
- To grill meat, put the temperature at maximum and make sure that the grill has been fully preheated. You may adjust the temperature as you cook.
- Use a wooden or a heat-resistant plastic spatula when cooking to avoid scratching the non-stick coating of the pan. Avoid using metal/sharp utensils.

CLEANING INSTRUCTIONS

- Switch the appliance off.
- Always unplug from the main socket and wait for the appliance to cool down before cleaning.
- Wash the plate and the drip tray with warm water and soapy sponge.
- To remove stubborn food residue, spread a small amount of cooking oil to the heating plate and gently remove the residue with a wooden/plastic spatula.
- Do not use a metal scouring pad or any abrasive objects to clean the heating plate.
- Do not use acidic or abrasive detergents.
- Do not immerse the controller in water.
- After washing, dry the plate thoroughly, paying particular attention to the electrical socket and pins.

MAINTENANCE

- Always allow the griller to completely cool down before cleaning and storing.
- Store the griller in a dry location, such as tabletops, countertops or cupboard shelves.
- Wind the electrical cord into a coil and secure with a twist fastener.
- Other than the recommended cleaning instructions, no other maintenance is necessary.

PRODUCT SPECIFICATIONS

Model: CONSD35X35SGRATELC

Power Consumption: 1,500 W

Voltage: 230V~60Hz

ATTENTION: If the power lead is damaged, it should be replaced by the manufacturer to avoid any danger. Contact Condura's customer service hotline for repairs.

Customer Care

We are committed to serve.

QUESTIONS ABOUT YOUR CONDURA SMOKELESS GRILLER

Please feel free to contact any of our customer care hotline*:

CUSTOMER SERVICE DEPARTMENT

GMA & LUZON Area

Address: 308 Sen. Gil Puyat Avenue, Makati City

Trunk Line: (02) 8 863 5555

TOLL FREE: 1800 10 888 8888

Mobile Number: +63 917 536 3030 (Globe) "SMS Only"

+63 947 996 2415 (Smart) "SMS Only"

Covered Region/Areas: National Capital Region (NCR), Ilocos Region (Region 1), Cordillera Administrative Region (CAR), Central Luzon (Region III), CALABARZON (Region IV-A), MIMAROPA except Romblon (Region IV-B), Bicol Region except Masbate (Region V)

Email Address: customercare@condura.com

CEBU Regional Office

Address: Dr. A Esperanza Building, A.C Cortes Ave. Mandaue City

Telefax No: 032 328 1416

Mobile Number: +63 947 996 2416

+63 921 222 0942

TOLL FREE: 1800 10 888 8888

Covered Region/Area: Masbate, Central Visayas (Region VII), Eastern Visayas (Region VIII)

ILOILO Regional Office

Address: 109 Yulo Street, Brgy. Yulo-Arroyo, Iloilo City, Iloilo

Telefax No: 032 36 1121

Mobile Number: +63 947 996 2417

+63 999 925 5736

TOLL FREE: 1800 10 888 8888

Covered Region/Area: Romblon, Western Visayas (Region VI)

CAGAYAN DE ORO Regional Office

Address: No. 102 CKY Center, Capistrano-Chavez Street, CDO City

Telefax No: 08822 721 905

Mobile Number: +63 947 996 2419

+63 939 253 5011

TOLL FREE: 1800 10 888 8888

Covered Region/Area: Zamboanga Peninsula (Region IX), Northern Mindanao (Region X), Autonomous Region in Muslim Mindanao (ARMM) except Maguindanao, Agusan Del Norte, Surigao del Norte

DAVAO Regional Office

Address: 1C, Nand-Saling Building, Sobrecarey Street, Obrero, Davao City

Telefax No: 082 224 5040

Mobile Number: +63 947 996 2418

+63 922 294 1478

TOLL FREE: 1800 10 888 8888

Covered Region/Area: Davao Region (Region XI), SOCCSKSARGEN (Region XIII), Agusan Del Sur, Surigao del Sur, Maguindanao

All contact information detailed above may change without prior notice.



CONCEPCION DURABLES INCORPORATED

CUSTOMER SERVICE DEPARTMENT

308 Sen. Gil Puyat Avenue, Makati City

Trunk Line: (02) 8 863 5555

TOLL FREE: 1800 10 888 8888

**Mobile Nos.: 0917 536 3030 (Globe)
0947 996 2415 (Smart)**

PO BOX 211 COMMERCIAL CENTER

MAKATI CITY

**BUSINESS REPLY!
Permit No. 2416A!
NO STAMP NEEDED**

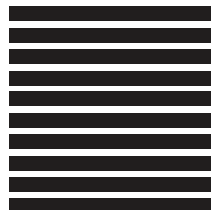

CONDURA

PRODUCT WARRANTY CERTIFICATE

IMPORTANT: PLEASE READ CAREFULLY

Concepcion Durables, Inc. ("CDI") warrants to the purchaser that this CONDURA SMOKELESS GRILLER will be free from defects in material and workmanship, and agrees to repair or replace any defective part or unit with a new or equivalent part or unit through any of its Authorized Service Centers if such defect is found to be manufacturer's error and in accordance with the terms of this warranty, subject to the following conditions:

1. COVERAGE OF WARRANTY

Applicable for Condura Smokeless Griller

2. WARRANTY PERIOD (from the date of original purchase)

System Parts and labor.....1 Year

CDI warrants this Smokeless Griller to the original purchaser/user to be free from defects in materials and workmanship under normal use.

CDI shall, at no cost to the original purchaser/user, repair or replace the unit or any of its parts that is found by CDI to be actually defective within the Warranty Period, with original or equivalent unit or parts, subject to the conditions and exclusions provided below.

3. LIMITATIONS

This warranty is not transferable, valid only in the Philippines. This warranty shall be void if the unit is:

- Improperly installed or mounted, or subjected to misuse, abuse, neglect, accident, alteration or abnormal voltage conditions
- Plugged into any device other than a suitable power supply outlet
- Serviced, opened, dismantled, disassembled, or reassembled by anyone other than a CDI accredited service center
- Damaged in transport or subjected to rough handling
- Damaged due to rodent, pest, or related infestation
- Damaged due to commercial use (stores, restaurants, other businesses, and non-household application)
- Damaged due to accidents, flood, fire, etc.

This warranty does not cover breakable parts and accessories, and any damages due to wear and tear.

The above warranties are given by CDI in lieu of any other warranties, express or implied. CDI and its vendors disclaim any implied warranty of merchantability or fitness for a particular purpose or any similar standard imposed by applicable legislation. CDI's responsibility to repair, replace or offer a refund for defective units, parts and related items is the sole and exclusive remedy provided for breach of these warranties.

MODEL NO. SERIAL NO.

NOTE: Keep this warranty card together with your Original Sales Invoice /Official Receipt as proof of purchase. If the date of purchase cannot be proven, warranty shall be based on CDI's Invoice to Dealer.



Fill out this warranty card completely and mail within 15 days from date of purchase. This will activate your warranty.



MODEL NO. SERIAL NO.
DEALER (Please indicate branch)
DATE OF PURCHASE **DEALER INVOICE NO.**
CUSTOMER NAME **EMAIL ADDRESS**
ADDRESS
TELEPHONE NO. MOBILE NO.



www.CONDURA.com