

# CONDURA

## PERSONAL REFRIGERATOR

CPR48MN-R



CONDURA  
KAYANG-KAYA!

---

# Table of contents

- |          |                           |          |                         |
|----------|---------------------------|----------|-------------------------|
| <b>1</b> | Parts                     | <b>5</b> | Food Storage            |
| <b>2</b> | Handling and Installation | <b>6</b> | Defrosting and Cleaning |
| <b>3</b> | Getting Started           | <b>7</b> | Safety Instructions     |
| <b>4</b> | Temperature Control       | <b>8</b> | Basic Troubleshooting   |
-

# 1

## PARTS

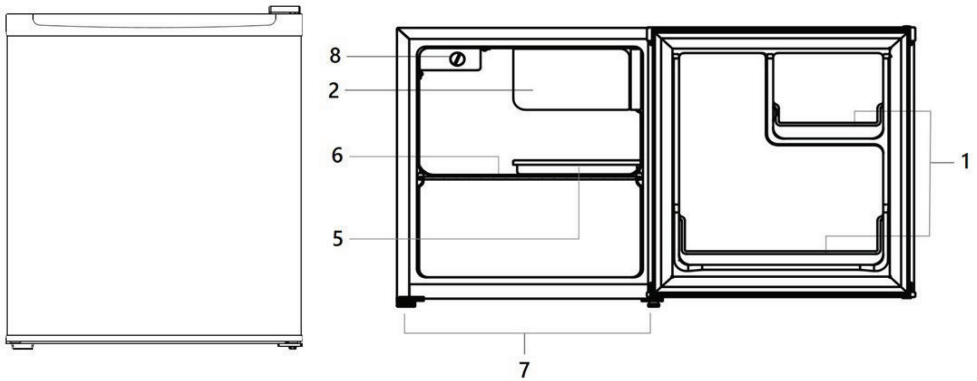

No.	Part Description	CPR48MN-R
1	Door Racks	2
2	Freezer Door	1
3	Ice Tray	1
4	Ice Scraper	1
5	Drip Tray	1
6	Shelf	1
7	Leveller	2
8	Temperature Control Dial	1
Color		Inox
Net Volume (Liters)		48 L
Unit Dimension (WxDxH)		440mm x 460mm x 510mm
Voltage / Cycle		230V / 60Hz
Defrosting System		Manual

Actual design and location of accessories may vary depending on model.  
Specifications and features are subject to change without prior notice.

# 2

## HANDLING & INSTALLATION

When moving the ref, hold the base and lift carefully at an angle not more than 45 degrees.

Do not place the ref horizontally or upside down.

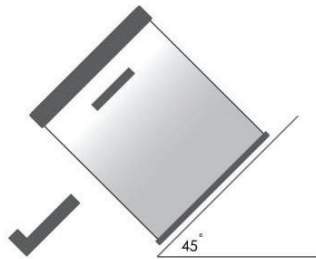

For proper ventilation, leave at least 12 inches of space between ref and ceiling or overhead pit; and 2 inches of space between ref and wall.

**Place the refrigerator on a flat and firm ground for stability.**

Keep the refrigerator in a well-ventilated area. Choose a location where there is no heat source like direct sunlight, oven, etc.

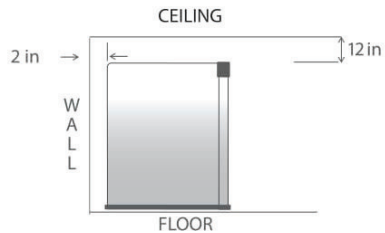

### Leveling the Unit

To do this adjust the two leveling feet at the front of the unit.

If the unit is not level, the door and magnetic seal alignments will not be covered properly.

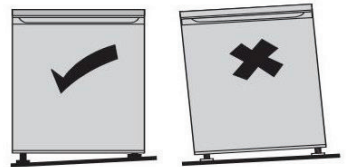

# 3

## GETTING STARTED



Wait for **SIX HOURS BEFORE PLUGGING** your ref to make sure that motor oil has settled down. The temperature control knob should be in "OFF" position.

Plug the refrigerator directly to a 230V-wall outlet. Upon plugging, anticipate the humming sound of the compressor and check the light inside the ref is turned on.

Do not use extension cord.

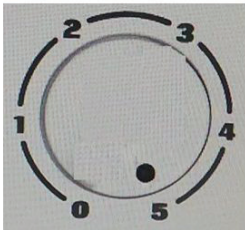

For CPR48MN-R. Turn the temperature control knob to "5" or coldest setting and allow to cool for "4" hours before loading food and beverage items.



- **Before Plugging in YOU MUST**

Check that you have a socket which is compatible with the plug supplied with the unit.

- **Before Turning On!**

Do not turn on until six hours after moving the unit. The coolant fluid needs time to settle.

---

# 4

## TEMPERATURE CONTROL

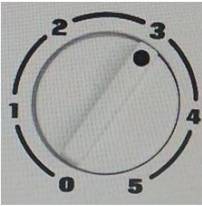

To adjust to desired temperature, turn the control knob clockwise or counter-clockwise.

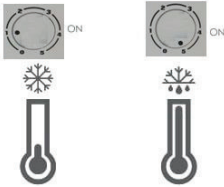

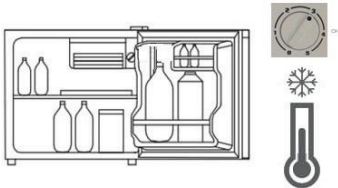

The "5" setting denotes the coldest temperature while the "1" setting denotes the warmest.



Adjust the temperature according to refrigerator load. For normal load, set the control knob at "3-4" or "MID" setting.

---

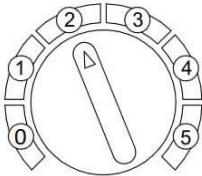
## Recommended Temperature Setting

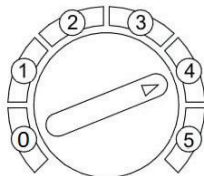
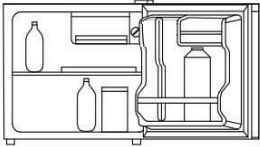
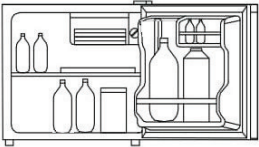
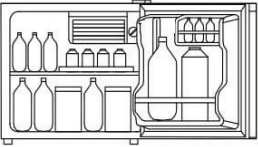
	Setting No. 1 to 2	Setting No. 3	Setting No. 4 to 5
	 <p>Set the control knob to no. 1 to 2 when storing MINIMUM amount of food and beverage items.</p>	 <p>Set the control knob to no. 3 when storing MODERATE amount of food and beverage items.</p>	 <p>Set the control knob to no 4 to 5 when storing LARGE amount of food and beverage items.</p>
<b>CPR48MN-R</b>			

### Noises Inside the Unit!

You may notice that your unit makes some unusual noises. Most of these are perfectly normal, but you should be aware of them!

These noises are caused by the circulation of the refrigerant liquid in the cooling system. It has become more pronounced since the introduction of CFC free gases. This is not a fault and will not affect the performance of your unit. This is the compressor motor working, as it pumps the refrigerant around the system.

---

# 5

## FOOD STORAGE



Cool down food to room temperature before putting it inside the ref.



Place food in airtight containers/ plastic.

### Tips for Keeping Food in the Unit

- Cooked meats/fishes should always be stored on a shelf above raw meats/fishes to avoid bacterial transfer. Keep raw meats/fishes in a container which is large enough to collect juices and cover it properly. Place the container on the lowest shelf.
  - Leave space around your food, to allow air to circulate inside the unit. Ensure all parts of the unit are kept cool.
  - To prevent transfer of flavours and drying out, pack or cover the food separately. Fruit and vegetables do not need to be wrapped.
  - Always let pre-cooked food cool down before you put in the unit. This will help to maintain the internal temperature of the unit.
  - To prevent cold air escaping from the unit, try to limit the number of times you open the door. We recommend that you only open the door when you need to put food in or take food out.
-



---

# 6

## DEFROSTING & CLEANING

When frost in freezer is already one-fourth inch (1/4") thick or more, it is time to DEFROST:

1. Turn OFF the temperature control knob then unplug the ref.
2. Remove all contents and detachable accessories.
3. After all the ice has melted, clean your ref with lukewarm water and mild soap. Wipe off using a soft, dry cloth.



Do not use a metal or sharp instrument to scrap away the frost, nor should you use any electrical appliances to aid defrosting.

### USEFUL TIPS

- **When cleaning your refrigerator, do not use bleach, heavy detergent, or other abrasive cleaners.**
- **Do not scrape ice using sharp and pointed metal tools to avoid damage and misuse, this voids warranty.**
- **If you have to leave your ref unused for a long time, it is recommended that you leave your personal ref empty, clean and unplugged. Keep the door open to prevent growth of mold and mildew.**

Condensation may appear on the outside of the unit. This may be due to a change in room temperature. Wipe off any moisture residue. If the problem continues, please contact a qualified technician for assistance.

---

---

# MAINTENANCE AND DISPOSAL

## Maintenance

---

### Care When Handling / Moving the Unit

Hold the unit around its sides or base when moving it. Under no circumstances should it be lifted by holding the edges of the top surface.

### Servicing

The unit should be serviced by an authorized engineer and only genuine spare parts should be used. Under no circumstances should you attempt to repair the unit yourself. Repairs carried out by inexperienced persons may cause injury or serious malfunction. Contact a qualified technician.

### Switching Off for Long Periods of Time

When the unit is not in use for a long period of time, disconnect it from the mains supply, empty all food and clean the appliance, leaving the door ajar to prevent unpleasant smells.

## Disposal

---

Old units still have some residual value. An environmentally friendly method of disposal will ensure that valuable raw materials can be recovered and used again. The refrigerant used in your unit and insulation materials require special disposal procedures. Ensure that none of the pipes on the back of the unit are damaged prior to disposal.

Up to date information concerning options of disposing of your old unit and packaging from the new one can be obtained from your local council office.

When disposing of an old unit break off any old locks or latches and remove the door as a safeguard.

---

---



## SAFETY INSTRUCTIONS

### A. POWER CORD

- Refrain from using an extension cord, octopus connection to prevent circuit overloading.
- The power cable tension must be a little loose when plugged.
- Keep the power cable away from the compressor.
- Do not attempt to replace or repair damaged power cord. Call customer hotline or any authorized service center immediately.
- When touching or cleaning the plug, make sure your hands and rug are dry.
- When unplugging, always grip the plug firmly and do not yank the power cord.
- Do not plug refrigerator in loose sockets.
- Ensure that the power cord is not bent excessively or pressed down by a heavy object.

### B. STORAGE

- Do not store, use gasoline or any other flammable items near by the refrigerator.
- Storing hazardous materials, such as ether and benzyne, can cause an explosion.
- Do not store bottled drinks in the freezer.

### C. HANDLING

- Never use flammable agents when cleaning the ref and its parts.
- Call customer care hotline or any authorized service center immediately if problem/s are encountered.
- Do not touch the freezer's inner wall with wet hands to avoid frost bite.
- Avoid water contact in areas near the temperature control knob to prevent shock hazards.
- Do not damage the refrigerant circuit.
- Do not place heavy item/s on top of the refrigerator.

### D. DISPOSAL

Please contact local authorities for the proper disposal of your refrigerator.  
The gas in the insulation material requires special disposal procedure.

### CAUTION or WARNING

- This appliance is not intended for use by persons (including children) with reduced physical, sensory or mental capabilities, or lack of experience and knowledge, unless they have been given supervision or instruction concerning use of the appliance by a person responsible for their safety.
  - In case of brownouts, wait at least five (5) minutes before turning the refrigerator's power up.
  - Do not use sharp objects or tools that may cause damage to the refrigerant circuit
  - Do not use electrical appliances inside the food storage compartment.
  - The lamp must not be replaced by user! Call customer service hotline for replacement.
-

---

# 7

## SAFETY INSTRUCTIONS

### **FLAMMABLE - REFRIGERANT GAS**

Risk of fire or explosion. Flammable refrigerant used. Do not use mechanical devices to defrost refrigerator. Do not puncture refrigerant tubing.

Risk of fire or explosion. Flammable refrigerant used. To be repaired only by trained service personnel. Do not puncture refrigerant tubing.

Risk of fire or explosion. Flammable refrigerant used. Consult repair manual/use and care guide before attempting to service this product. All safety precautions must be followed.

Risk of fire or explosion. Dispose of property in accordance with federal or local regulations. Flammable refrigerant used.

Risk of fire or explosion due to puncture of refrigerant tubing. Follow handling instructions carefully. Flammable refrigerant used.



IT IS HAZARDOUS FOR ANYONE OTHER THAN AUTHORIZED SERVICE PERSONNEL TO CARRY OUT SERVICING OF REPAIRS WHICH INVOLVE THE REMOVAL OF COVERS.



TO AVOID THE RISK OF AN ELECTRICAL SHOCK DO NOT ATTEMPT REPAIRS YOURSELF.



DO NOT USE AN EXTENSION CORD.



**DANGER:** Risk of child entrapment. Before you throw away your old refrigerator:

- Take off the doors.
  - Leave the shelves in place so that children may not easily climb inside.
-

# 8

## BASIC TROUBLESHOOTING

PROBLEM	POSSIBLE CAUSE
1. When refrigerator would not turn ON:	<ol style="list-style-type: none"> <li>1. The power cord is not properly plugged.</li> <li>2. The temperature control knob is in "OFF" position.</li> </ol>
2. When refrigerator is not cooling:	<ol style="list-style-type: none"> <li>1. The temperature control knob is not set according to refrigerator load.</li> <li>2. The refrigerator &amp; freezer doors are not properly closed.</li> <li>3. The lamp remains on while the ref door is being closed.</li> </ol>
3. When the refrigerator emits foul odor:	<ol style="list-style-type: none"> <li>1. There is spoiled food or drink inside the refrigerator.</li> <li>2. The refrigerator is not thoroughly cleaned after defrosting.</li> </ol>
4. When there is dew or moisture in the vegetable compartment:	<ol style="list-style-type: none"> <li>1. The ref door is not tightly closed.</li> <li>2. The crisper pan is not pushed all the way back.</li> </ol>
5. When there is sweating in the exterior ref cabinet during cold weather:	<ol style="list-style-type: none"> <li>1. The temperature control knob is not set according to refrigerator load.</li> <li>2. The refrigerator &amp; freezer doors are not properly closed.</li> </ol>
6. When refrigerator makes "unusual noise" like sizzling, ticking or humming:	<p>Please note that these may be normal sounds that indicate that your ref is working properly:</p> <p>"Sizzling" - This indicates that the refrigerant is passing through the freezer compartment</p> <p>"Ticking" - This indicates that the thermostat control is turning on and off.</p> <p>"Humming" - This is the sound of the motor, working.</p>

If problem still occurs after checking all items above, please call our "Customer Care Hotlines":

Trunkline : 02 8 863 5555  
 TOLL FREE : 1800 10 888 8888  
 Globe : +63 917 536 3030  
 Smart : +63 947 996 2415

\*Numbers are subject to change without prior notice

**Please prepare the following information to be relayed to the Customer Care Representative who will take your call:**

- Customer ID No (if already previously assigned one)
- Customer Name
- Address (House No., Block / Lot, Street, Subdivision, Barangay, City and Nearest Landmarks)
- Model & Serial No of your refrigerator (found on the sticker inside ref)
- Dealer Branch (where the unit was purchased)
- Date of purchase (according to sales invoice / receipt)
- Complaint or problem encounter

You may also scan the provided QR code to book a service



**Scan QR code for  
 service needs**

**CONDURA**  
***KAYANG-KAYA!***

**[www.condura.com](http://www.condura.com)**

Fill-up this warranty card completely and mail within 15 days from date of purchase. This will activate your warranty from Condura!

**CONDURA**

MODEL NO.: \_\_\_\_\_ SERIAL NO.: \_\_\_\_\_  
DEALER: \_\_\_\_\_ BRANCH: \_\_\_\_\_  
DATE OF PURCHASE: \_\_\_\_\_ DEALER INVOICE NO.: \_\_\_\_\_  
CUSTOMER NAME: \_\_\_\_\_ EMAIL ADDRESS: \_\_\_\_\_  
ADDRESS: \_\_\_\_\_  
TELEPHONE NO.: \_\_\_\_\_ MOBILE NO.: \_\_\_\_\_

I consent to the collection, processing and use by Concepcion Durables, Inc. (CDI) of the data above for the purposes identified in its Data Privacy Notice published in its website ([www.condura.com](http://www.condura.com)), which is deemed incorporated into this Warranty Card.

**CONDURA**

## PRODUCT WARRANTY CERTIFICATE

### IMPORTANT: PLEASE READ CAREFULLY

Concepcion Durables, Inc. (CDI) warrants the purchaser, that this CONDURA refrigerator will be free from defective material and workmanship, and agrees to repair, or at its discretion, replace any defective material with a new or equivalent part, through any of its Authorized Service Centers, only if found to be manufacturer's defect and in accordance with the terms of this warranty, subject to the following conditions:

### 1. WARRANTY PERIOD (from the date of original purchase)

CONDURA		WARRANTY
1 year	-----	SYSTEM PARTS & LABOR (Refrigerant, Filter Drier, Motor Relay, & Freezer Coil), Lamp
5 years	-----	COMPRESSOR (Motor only. Does NOT include System Parts & Labor
NO Warranty	-----	Glass Shelves, Crisper Glass cover, Power Cord, Plastic Parts (bottle racks, crisper pan, rubber gasket)

There will be corresponding charges for labor and replacement parts after the warranty period.

### 2. COVERAGE OF WARRANTY

The CONDURA warranty is also applied to refrigerators used for household purpose only

### 3. LIMITATIONS

This warranty is not transferable, valid only in the Philippines, and does not apply to damage(s) due to fire, improper use or abuse (punctured), force majeure (typhoon, flood, lightning, earthquake, etc.), use with voltages beyond the allowable range of 198V to 242V, or failure to follow operating instructions, provided in the manual, if the serial number is removed or defaced, or if the unit has been tampered with, altered or in any way repaired, serviced or worked on by anyone other than a duly authorized representative or Service Center, this warranty is considered null and void. Concepcion Durables, Inc. (CDI) offers this warranty as the only remedy available to the original purchaser for any defect, that may arise within the warranty period. Correction of defects shall be considered as complete fulfillment of liabilities and responsibilities of CDI to the original purchaser. In no event shall CDI be held liable for any damage or consequence that may arise as a result of using this CONDURA product.

MODEL NUMBER: \_\_\_\_\_ SERIAL NUMBER: \_\_\_\_\_

NOTE: Keep this warranty card together with your Original Sales Invoice / Official Receipt as proof of purchase. If the date of purchase cannot be proven, warranty shall be based on CDI's invoice to Dealer.

**CONCEPCION DURABLES INCORPORATED**  
**CUSTOMER SERVICE DEPARTMENT**

308 Sen. Gil Puyat Avenue, Makati City

Trunk Line: 02 8 863 5555

TOLL FREE: 1800 10 888 8888

Mobile Nos.: 0917 536 3030 (Globe) "SMS Only"  
0947 996 2415 (Smart) "SMS Only"

**P.O. BOX 211 COMMERCIAL CENTER**  
**MAKATI CITY**

**BUSINESS REPLY**  
**PERMIT No. 2416A**  
**NO STAMP NEEDED**

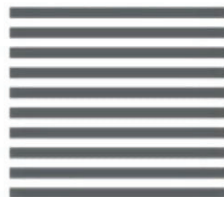

**CONCEPCION DURABLES INCORPORATED**

**CUSTOMER SERVICE DEPARTMENT**

GMA & LUZON Area

Address: 308 Sen. Gil Puyat Avenue, Makati City

Trunk Line: 02 8 863 5555

TOLL FREE: 1800 10 888 8888

Mobile Number: +63 917 536 3030 (Globe) "SMS Only"  
+63 947 996 2415 (Smart) "SMS Only"

Covered Region/Areas: National Capital Region (NCR), Ilocos Region (Region I), Cordillera Administrative Region (CAR), Central Luzon (Region III), CALABARZON (Region IV-A), MIMAROPA except Romblon (Region IV-B), Bicol Region except Masbate (Region V)

Email Address: [customercare@condura.com](mailto:customercare@condura.com)

**CEBU Regional Office**

Address: Dr. A Esperanza Building, A.C Cortes Ave. Mandaue City

Telefax No: 032 328 1416 / 032 347 3380

Mobile Number: +63 947 996 2416

+63 921 222 0942

TOLL FREE: 1800 10 888 8888

Covered Region/Area: Masbate, Central Visayas (Region VII), Eastern Visayas (Region VIII)

**ILOILO Regional Office**

Address: 109 Yulo Street, Brgy. Yulo-Arroyo, Iloilo City, Iloilo

Telefax No: 033 336 1121

Mobile Number: +63 947 996 2417

+63 999 925 5736

TOLL FREE: 1800 10 888 8888

Covered Region/Area: Romblon, Western Visayas (Region VI)

**CAGAYAN DE ORO Regional Office**

Address: No. 102 CKY Center, Capistrano-Chavez Street, CDO City

Telefax No: 088 881 0615

Mobile Number: +63 947 996 2419

+63 939 253 5011

TOLL FREE: 1800 10 888 8888

Covered Region/Area: Zamboanga Peninsula (Region IX), Northern Mindanao (Region X), Autonomous Region in Muslim Mindanao (ARMM) except Maguindanao, Agusan del Norte, Surigao del Norte

**DAVAO Regional Office**

Address: 1C, Nand-Saling Building, Sobrecarey Street, Obrero, Davao City

Telefax No: 082 291 7276

Mobile Number: +63 947 996 2418

+63 922 294 1478

TOLL FREE: 1800 10 888 8888

Covered Region/Area: Davao Region (Region XI), SOCCSKSARGEN (Region XII), Agusan del Sur, Surigao del Sur, Maguindanao