

CONDURA

NO FROST SIDE BY SIDE INVERTER REFRIGERATOR

CSS207i



CONDURA









TABLE OF CONTENTS

SAFETY INFORMATION	2 - 3
PRODUCT PARTS IDENTIFICATION	4
START UP OPERATION	5
TEMPERATURE CONTROL SETTING GUIDE	6 - 8
FOOD STORAGE TIPS / DEFROSTING	9
CLEANING, CARE AND MAINTENANCE	10
TROUBLESHOOTING	11
ENERGY SAVING TIPS	12

SAFETY INFORMATION (DO's and DONT'S)

Before operating the refrigerator, please read the following information in the owner's manual thoroughly and keep it for your reference. Failure to observe these safety guidelines could result in fire, electric shock, injuries, or damage to your refrigerator and/or other properties.

CAUTION / WARNING:

-  This appliance is not intended for use by persons (including children) with reduced physical, sensory or mental capabilities, or lack of experience and knowledge, unless they have been given supervision or instruction concerning use of the appliance by a person responsible for their safety. Children should be supervised to ensure that they do not play with the appliance.
-  Do not use sharp objects or tools that may cause damage to the refrigerant circuit.
-  Do not use electrical appliances inside the food storage compartments of the appliance.
-  The LED Light must not be replaced by user! If the LED Light is damaged, it is highly recommended to have our authorized service personnel to do the replacement for you.
-  Do not use extension cord.
-  When positioning the appliance, ensure the supply cord is not trapped or damaged.
-  Do not locate multiple portable socket-outlets or portable power supplies at the rear of the appliance.
-  This appliance is intended for household use and similar applications such as:
 - staff kitchen areas in shops, offices and other working environments;
 - farm houses and by clients in hotels, motels and other residential type environments.
 - bed and breakfast type environments;
 - catering and similar non-retail applications

SAFETY INFORMATION (DO's and DONT'S)

A) POWER/SUPPLY CORD

- 1) Plug the unit properly into a wall outlet with its required voltage.
- 2) Please ensure a minimum clearance of 2" (inch) for air ventilation and to prevent damage to the supply cord.
- 3) When touching or cleaning the plug, make sure your hands and rug are dry.
- 4) Do not plug the refrigerator into a loose socket. There will be a risk of electric shock or fire.

B) STORAGE AND HANDLING

- 1) Storing hazardous materials, such as ether and benzyne, can cause explosions.
- 2) DO NOT store bottled drinks in the freezer.
- 3) DO NOT touch the freezer's inner wall with wet hands to avoid frost bites.
- 4) Avoid water contact in areas near the temperature control knob to prevent shock hazards.

C) DISPOSAL

Please contact local authorities in regard to the safe disposal of this product. Ensure that none of the pipes on the back of the product are damaged prior to disposal.

WARNING:

The refrigerant of this No Frost Top Mount Inverter cooling system contains R600a refrigerant.

The gas is flammable. Therefore, pay attention to not damaging the cooling system and piping during usage and transportation. In the event of damage, keep your product away from potential fire sources that may cause fire.

For Maintenance / Service:

Call Customer Hotline / Trunkline:

#88635555

Instructions for replacement of supply cord:

If the supply cord is damaged, it must be replaced by the manufacturer, authorized service personnel in order to avoid a hazard.

PRODUCT OVERVIEW

Parts and functions

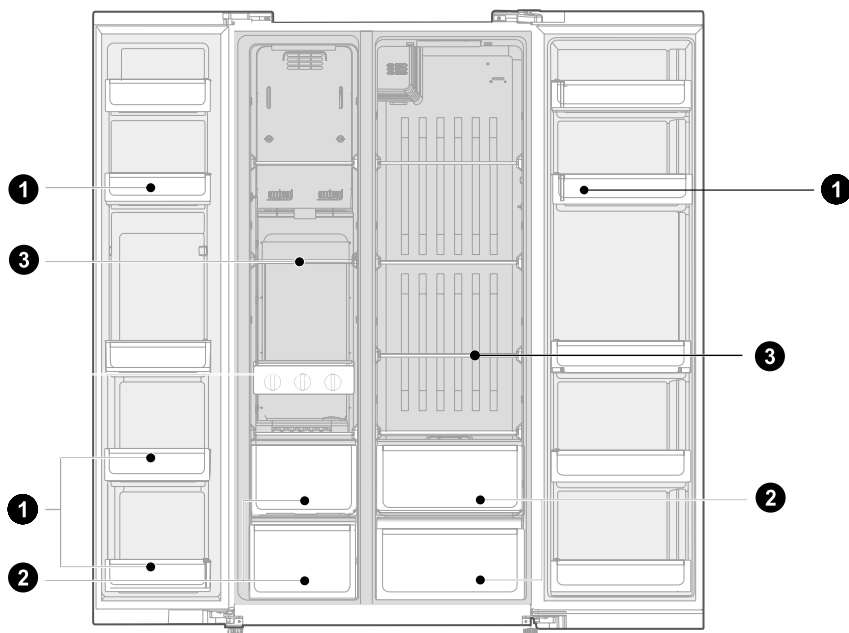

No	Parts Description	CSS207i
1	Bottle Racks - Freezer / Fridge	5 pcs / 5 pcs
2	Drawer - Freezer / Fridge	2 pcs / 2 pcs
3	Tempered Shelf - Freezer / Fridge	4 pcs / 4 pcs
-	Egg Tray	2 pcs / 12 eggs slot
-	Ice Twist Maker	YES
Gross / Net Volume (Liters)		587 / 548
Freezer / Fridge Volume (Liters)		201 / 347
Unit Dimension WxDxH (mm)		897 x 706 x 1765
Refrigerant		R600a
Color Code		BLACK GLASS
Voltage (V) Cycle (Hz)		220-240 / 60
Defrosting System		Automatic / No Frost

The actual design and location of accessories may vary depending on the model. Specifications and features are subject to change without prior notice.

START-UP OPERATION

Congratulations! and thank you for your purchase.

- Install the unit in a well-ventilated location.
- The start-up of the unit (compressor) will be after 3 minutes.
- Leave at least 2 inches of space between ref and wall and 12 inches of space between ref and ceiling or overhead cabinet.
- Upon delivery, let the motor oil settle down for 3-4 hours before plugging in the product.
- Plug the product directly to a wall outlet (220-240V) and set the temperature control knob to Setting No. 4.
- To compensate for floor unevenness, adjust clockwise or counterclockwise the leveler located on the lower front corners of your refrigerator. It is recommended that the unit be slightly tilted backward to allow defrosting water to flow inward during defrosting.
- For safety reasons, it is advisable to ground the unit by connecting the ground wire provided at the back of the unit.

CAUTION / WARNING:

- Place refrigerator on a firm and flat surface.
- Do not place the product near direct sunlight or heat sources.
- Do not use extension cord.

LEVELLING FEET

The refrigerator should stand firm to avoid vibration.

If required, adjust the leveling feet to compensate for the uneven floor.

The front should be slightly higher than the rear to aid in door closing.

Leveling feet can be turned easily by tipping the cabinet slightly.

Turn the leveling feet counterclockwise to raise the unit, clockwise to lower it.

If the doors are not at the same height, the door can be adjusted with a spanner.

A. Loosen locking nut counterclockwise.

B. Rotate the adjusting nut counterclockwise to adjust the height of door.

C. When the door is correctly aligned, tighten the locking nut clockwise.

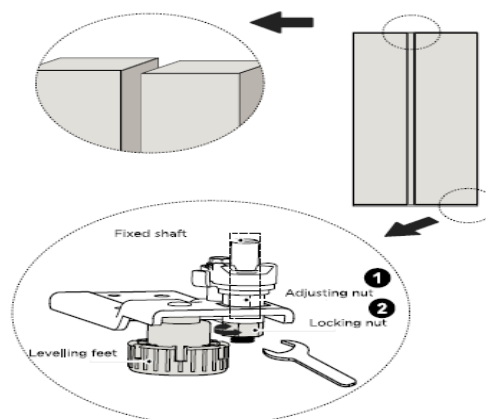

OPERATION INSTRUCTIONS

Use and functions

Feature panel

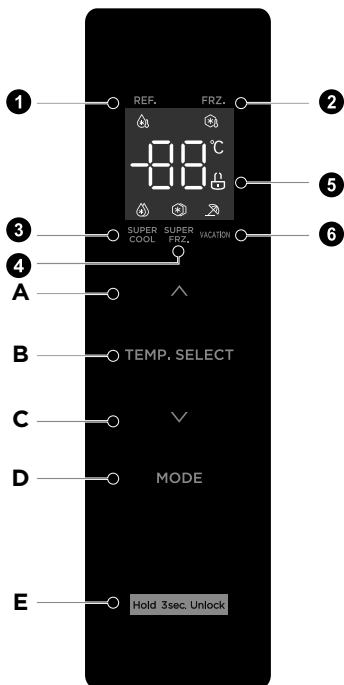

Display screen

- 1 Refrigerator
- 2 Freezer
- 3 Super cool
- 4 Super cool
- 5 Lock / unlock
- 6 Vacation

Button

- A Temperature up
- B Temperature range selection
- C Temperature down
- D Mode / function setting
- E Lock/unlock button

ATTENTION

Differences: Due to technical changes and different models, some of the illustrations in this manual may differ from your model.

Lock / unlock

In the non locking state, press the key “ **Hold 3sec.Unlock** ” for 3 seconds to enter the operation locking state, and the locking pattern is displayed. In the locked state, press the key “ **Hold 3sec. Unlock** ” for 3 seconds to display the unlocking “  ” pattern and unlock. After 30 seconds without key operation, the refrigerator will automatically enter the locked state.

The following functions must be operated in the unlocked state.

Mode setting

Press the key “**MODE**”, and the **super cooling**, **super freezing** and **vacation** modes cycle in the following ways:



In vacation mode, the temperature of the freezer is automatically set to -18°C , the refrigerating chamber is closed.

In the super cooling mode, the temperature of the refrigerating chamber is automatically set to 2°C ; When exiting the super cooling mode, the set temperature of the refrigerating chamber will automatically return to the set temperature before the super cooling mode.

Exit the super cooling mode if one of the following conditions is met:

- A:** Exit the super cooling mode through key operation;
- B:** Rapid cooling time $\geq 6\text{h}$;

In the super freezing mode, the freezing chamber temperature is automatically set to -24°C ; When exiting the super freezing mode, the set temperature of the freezing chamber will automatically return to the set temperature before the super freezing mode.



Exit the super freezing mode when one of the following conditions is met:



- A:** Exit the super freezing mode by pressing the key;
- B:** super freezing time $\geq 24\text{h}$;

ATTENTION

The super-freezing function is designed to maintain the nutritional value of the food in the freezer. It can freeze the food in the shortest time. If a large amount of food is frozen at one time, it is recommended that the user turn on the super-freezing function and put the food in. At this time, the freezing speed of the freezer compartment is increased, which can quickly freeze the food, effectively lock the nutrition of the food, and facilitate storage.

Temperature setting of refrigerating chamber



Press the key “TEMP.SELECT” to select the refrigerating chamber “” freezing chamber “”, and the temperature zone icon and the set temperature of the corresponding icon will be displayed;

Select the room to be adjusted, and press the up temperature key “” to adjust the temperature upward. Each time you press it, the temperature will be increased by 1 degree; Select the room to be adjusted, press the down temperature key “” to adjust the temperature downward. Each time you press it, the temperature will be reduced by 1 degree;

The setting range of refrigerating chamber is 2 and 8°C , and the setting range of freezing chamber is -24 and -16°C ; The new set temperature takes effect after locking. When it is set to the boundary value, pressing the corresponding temperature adjustment key will prompt the key invalid sound.

Recommended setting: Refrigerated chamber 4°C , freezing chamber -18°C .

Door opening prompt tone

When the refrigerator door is opened, the door opening music ring. At the same time, long press the “” + “” combination key for 3 seconds to turn on / off the door opening prompt tone (on by default).

Door opening alarm

When the refrigerator door is not closed for more than 120 seconds, the refrigerator sounds an alarm sound, indicating that the door is not closed. Please close the door in time or click any key in the operation area of the display screen to close the alarm sound. (If the door is not closed for a long time, the food will be damaged. Please close the door in time)

Storage upon power failure

In case of power failure, the instant working state will be locked and maintained till re-electrification.

Fault indication

The following warnings appearing on the display indicate corresponding faults of the refrigerator. Though the refrigerator may still have cold storage function with the following faults, the user shall contact a maintenance specialist for maintenance, so as to ensure optimized operation of the appliance.

Fault Code	Fault Description
E1	Temperature sensor failure of refrigerating chamber
E2	Temperature sensor failure of freezing chamber
E5	Freezing defrost sensor detection circuit error
E6	Communication error
E7	Ambient temperature sensor error

FOOD STORAGE TIPS

Keeping Food Fresh:

- Allow warm food or hot beverages to cool down to room temperature before storing them in your refrigerator. Put frozen food and beverage items in the fridge compartments to thaw.
- Do not keep the fridge or freezer door open for too long when storing or taking out food or beverage items.
- Wash and rinse fruits and vegetables to prolong their freshness. Dry before storing in the crisper pan.
- It is recommended to put leftover and smelly foods in sealed containers to prevent from spreading unnecessary odor inside the compartment.
- It is recommended to minimize the frequency of the door opening when storing large amount of food and beverages to help maintain the optimum cooling performance.
- Store fruits and vegetables inside the crisper to preserve its freshness and avoid excess

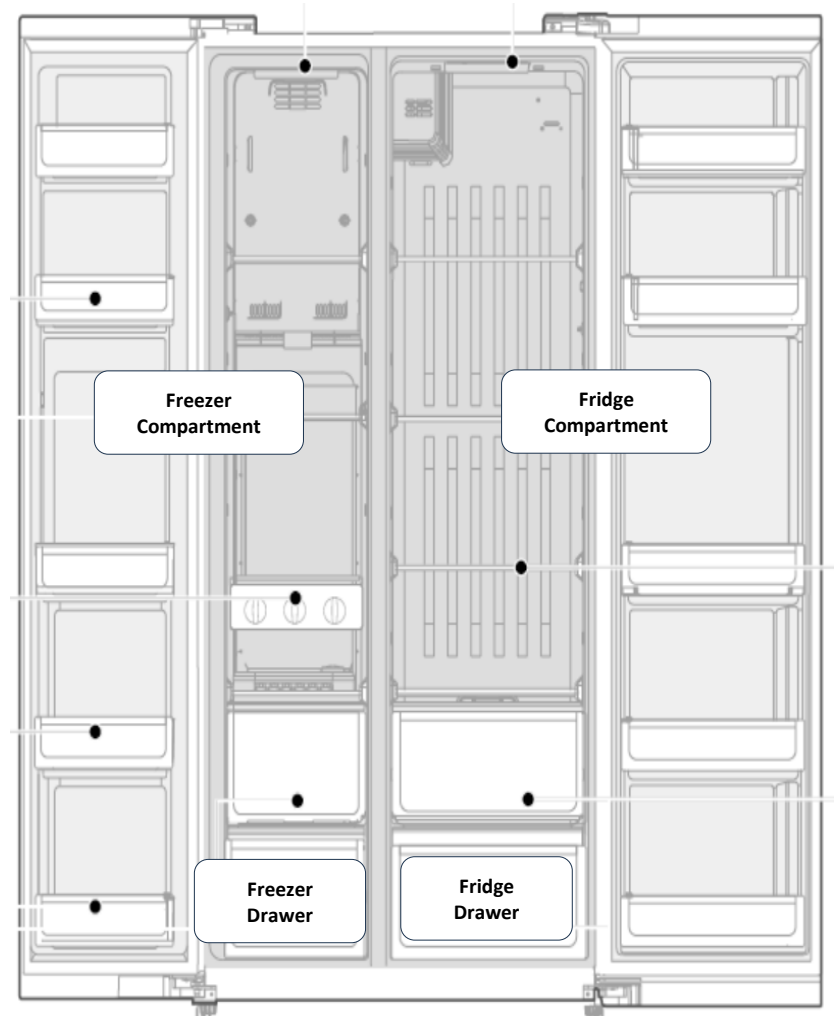

DEFROSTING

The Condura No Frost Inverter Refrigerator is designed to automatically defrost completely. Defrosted water from the evaporator will collect in the drain pan, where the accumulated water evaporates with the help of auxiliary tube.

WARNING:

Do not use mechanical devices or other means to accelerate the defrosting process, other than those recommended by the manufacturer.

CLEANING, CARE AND MAINTENANCE

Simple ways to make your refrigerator last (almost) a lifetime.

REFRIGERATOR CLEANING

Proper use of the No Frost Refrigerator Inverter ensures that it functions at an optimal level. It is important to regularly clean your fridge, or at least give it a wipe down, because of the build-up of mold and spillage from various perishable items kept in the fridge.

- **UNPLUG** No frost refrigerator. Remove all contents, including racks and shelves.
- **CLEAN** the racks, shelves, gasket, interior, and exterior of the refrigerator using a clean, damp cloth. Wipe it dry.
- **PLUG** your refrigerator directly into a 230V wall outlet.
- **WIPE** inside and outside of the refrigerator until it is clean and dry.

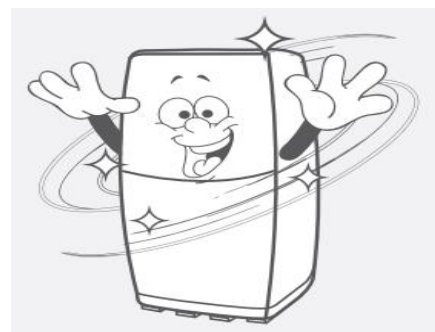

USING THE LEVELER

It is important to keep the refrigerator standing firm on a level surface to eliminate vibration and unnecessary noises during operation. Adjust the levelers found on both sides of the refrigerator to ensure its stability.

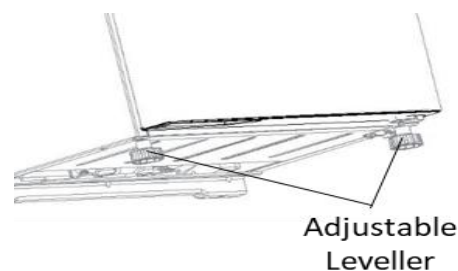

MOVABLE SHELVES

The walls of the refrigerator are equipped with a series of runners so that the shelves can be positioned as desired.

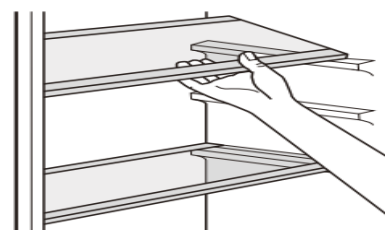

LED REPLACEMENT

It is recommended to have our authorized service personnel do the light replacement. Call our customer care hotlines for further assistance.



WARNING - Do not use electrical appliances inside the food storage compartments, unless they are of the type recommended by the manufacturer.

NOTICE:

Refrigerator's surface may become warm during operation - this is **NORMAL**. This indicates that the internal condenser tube is pumping heat around the cabinet to prevent condensation/sweating on the surface of the cabinet.

TROUBLESHOOTING

Things to check before calling our customer service hotlines.

 **Caution!** Before troubleshooting, disconnect the power supply. Only authorized service personnel must do the troubleshooting that is not in this manual.

PROBLEM	ACTION/S NEEDED
The refrigerator would not turn on or not working at all.	<ul style="list-style-type: none">• Check that the power or supply cord is properly connected.• Check the main fuse and electrical system of the house.
The fridge and freezer are not cooling enough.	<ul style="list-style-type: none">• Check that the freezer and fridge doors are tightly closed.• Check the storage of food and beverages; there must be enough space to allow air circulation.• Check that the control knob is at the proper setting based on the amount of load.• Check that the refrigerator is exposed directly to heat source.
The refrigerator cools too much	<ul style="list-style-type: none">• Ensure that there is no air vent blockage inside the freezer. Adjust the freezer damper if necessary and also, check if temperature was set properly based on the stored amount of load.
The refrigerator emits a foul odor	<ul style="list-style-type: none">• Check if there's no spoiled food or beverage inside the fridge.• Make sure that the strong-smelling food items are properly sealed.• There is no excessive accumulated defrost water in the drain pan.• The refrigerator is thoroughly cleaned.
The refrigerator makes unusual noises.	<ul style="list-style-type: none">• A refrigerator must be installed in a stable floor. Adjust the leveler.• Move the appliance slightly if it's possible to touch the wall or other objects. <p>Note that the noise may also come from the normal operation. Refrigerant passing through the system may cause sizzling sounds. On and Off Thermostat control operation may cause ticking sounds. The compressor can make a humming sound.</p>

TROUBLESHOOTING

If the problem still occurs after checking all items, please call our Customer Care. Hotlines:

Trunkline: #88635555

Smart: +63 947 996 2415 (SMS Only)

*Numbers are subject to change without prior notice

Please prepare the following information to be relayed to the

Customer Care Representative who will take your call:

- Customer ID No. (if already previously assigned one)
- Customer Name
- Address (House No., Block / Lot, Street, Subdivision, Barangay, City and nearest landmarks)
- Contact Nos. (Land line Nos. - House & Office, Cellphone Nos.)
- Model & Serial No. of your refrigerator (found on the sticker inside ref)
- Dealer Branch (where the unit was purchased)
- Date of Purchase (according to sales invoice/receipt)
- Complaint or problem encountered.

You may also scan the provided QR code to book a service.



Scan QR code for service needs



Scan QR code for videochat with Condura

ENERGY SAVING TIPS

Earn more and Save more.

Kindly follow guidelines below on how to reduce energy consumption for more energy savings.

- Cool down hot food items first before placing them inside the refrigerator. It will increase the interior temperature, which may affect the freshness of the food while being stored inside the refrigerator.
- DO NOT keep the fridge and freezer doors open for too long to prevent hot air from entering to reduce the amount of wasted electricity.
- DO NOT block the cold air outlet with food items when the cold air does not spread into every corner of the compartments. It will result to a higher electricity consumption.
- Temperature must be set properly according to the amount of food and beverages.
- Defrost and clean refrigerator regularly.

Fill-up this warranty card completely and mail within 15 days from date of purchase. This will activate your one (1) year warranty that is VALID FOR HOUSEHOLD USE. Only from Condura!

MODEL NO.: _____ **SERIAL NO.:** _____
DEALER: _____ **BRANCH:** _____
DATE OF PURCHASE: _____ **DEALER INVOICE:** _____
CUSTOMER NAME: _____ **EMAIL ADDRESS:** _____
ADDRESS: _____
TELEPHONE NO.: _____ **MOBILE NO.:** _____

I consent to the collection, processing, and use by Concepcion Durables, Inc. (CDI) of the data above for the purposes identified in its Data Privacy Notice published on its website (www.condura.com), which is deemed incorporated into this Warranty Card.



CONDURA

PRODUCT WARRANTY CERTIFICATE

IMPORTANT: PLEASE READ CAREFULLY

Concepcion Durables, Inc. (CDI) warrants the purchaser that this CONDURA refrigerator will be free from defective material and workmanship and agrees to repair, or at its discretion, replace any defective material with a new or equivalent part, through any of its Authorized Service Centers, only if found to be manufacturer's defect and in accordance with the terms of this warranty, subject to the following conditions:

1. WARRANTY PERIOD (from the date of original purchase)

- 2 years **LED LAMP, INVERTER BOARD & MAIN CONTROL BOARD**
- 1 year **SYSTEM PARTS & LABOR**
(Refrigerant, Filter Drier & Fin-Tube Assembly)
- 15 years **COMPRESSOR**
(MOTOR only. Does NOT include Systems Parts and Labor)
- No Warranty **PLASTIC PARTS (Freezer Door, Ref Door & Gasket)**
(Door racks, Tempered glasses and Supply cord)

There will be corresponding charges for labor and replacement parts after the warranty period.

2. COVERAGE OF WARRANTY

The CONDURA No Frost Inverter Warranty is applied to refrigerators used for household purposes only.

3. LIMITATIONS

This warranty is not transferable, valid only in the Philippines, and does not apply to damage(s) due to fire, improper use or abuse (punctured), force majeure (typhoon, flood, lightning, earthquake, etc.), use with voltages beyond the allowable range of 198V to 242V, or failure to follow operating instructions, provided in the manual, if the serial number is removed or defaced, or if the unit has been tampered with, altered or in any way repaired, serviced or worked on by anyone other than a duly authorized representative or Service Center, this warranty is considered null and void. Concepcion Durables, Inc. (CDI) offers this warranty as the only remedy available to the original purchaser for any defect, that may arise within the warranty period. Correction of defects shall be considered as complete fulfillment of liabilities and responsibilities of CDI to the original purchaser. In no event shall CDI be held liable for any damage or consequence that may arise as a result of using this CONDURA product.

MODEL NUMBER _____ **SERIAL NUMBER:** _____

NOTE: Keep this warranty card together with your Original Sales Invoice / Official Receipt as proof of purchase. If the date of purchase cannot be proven, warranty shall be based on CDI's invoice to Dealer.

**CONCEPCION DURABLES INC
CUSTOMER SERVICE DEPARTMENT**

BUSINESS REPLY
PERMIT No. 2416A
NO STAMP NEEDED

Km. 20 East Service Road, Alabang, Muntinlupa

TRUNK LINE: #88635555

Mobile Nos.: 0947 996 2415 (Smart) "SMS Only"

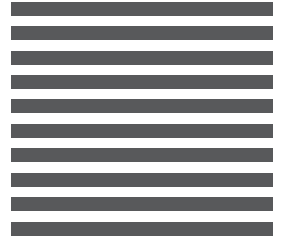

CUSTOMER SERVICE DEPARTMENT

GMA & LUZON AREA:

Address: Km. 20 East Service Road, Alabang, Muntinlupa

Trunk Line: #88635555

Mobile Number: +63 947 996 2415 (Smart) "SMS Only"

Covered Region/Areas: National Capital Region (NCR), Ilocos Region (Region I), Cordillera Administrative Region (CAR), Central Luzon (Region III), CALABARZON (Region IV-A), MIMAROPA Except Romblon, Bicol

Email Address: customercare@condura.com

CEBU Regional Office:

Address: Esperanza Bldg., AC Cortes St., Ibabao, Mandaue City Cebu

Landline: 32 328 1416

Mobile Number: '+63 947 996 2416 and '+63 999 887 1657

Covered Region/Area: Masbate, Central Visayas (Region VII), Eastern Visayas (Region VIII)

ILOILO Regional Office:

Address: 277 Iznart St., Brgy Danao, City Proper, Iloilo City

Landline: 33 336 1121

Mobile Number: +63 947 996 2417 and '+63 919 072 6530

Covered Region/Areas: Romblon, Western Visayas (Region VI)

CAGAYAN DE ORO Regional Office:

Address: 102 CKY Center, Capistrano St. corner Chaves St., Cagayan de Oro City

Landline: 88 881 0615

Mobile Number: +63 998 965 6756

Covered Region/Areas: Zamboanga Peninsula (Region IX), Northern Mindanao (Region X), Autonomous Region in Muslim Mindanao (ARMM) except Maguindanao, Agusan del Norte, Surigao del Norte

DAVAO Regional Office:

Address: 1C Nand Saling Bldg., Sobrecary St., Obrero, Davao City

Landline: 082 291 7276

Mobile Number: +63 998 965 6755

Covered Region/Area: Davao Region (Region XI), SOCCSKSARGEN (Region XII), Agusan del Sur, Surigao del Sur, Maguindanao

CONDURA

www.condura.com