

CONDURA

PERSONAL REFRIGERATOR

CPR51MN CG, CPR90TD Blk,
CPR90TD Wht, CPR90TD CG



CONDURA

Table of contents

1 Parts

2 Handling and
Installation

3 Getting Started

4 Temperature Control

5 Food Storage

6 Defrosting
and Cleaning

7 Safety
Instructions

8 Basic
Troubleshooting

1

PARTS

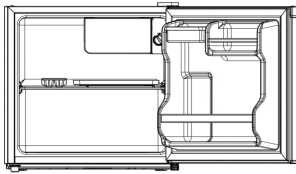

CPR51MN CG

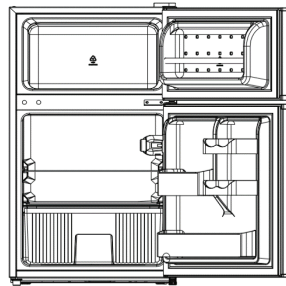

**CPR90TD Blk, CPR90TD Wht,
CPR90TD CG**

No.	Parts Description	CPR51MN CG	CPR90TD Blk	CPR90TD Wht	CPR90TD CG
1	Door Guard	2	1	1	1
2	Utility Rack	1	3	3	3
3	Door Rack	-	1	1	1
4	Freezer Door	1	1	1	1
5	Ice Tray	1	1	1	1
6	Ice Scaper	1	1	1	1
7	Drip Tray	1	N/A	N/A	N/A
8	Shelf	1	1	1	1
9	Crisper Cover	-	1	1	1
10	Crisper Pan	-	1	1	1
11	Egg Tray	-	1	1	1
12	Leveller	2	2	2	2
13	Drain Pan	-	1	1	1
Color		Cloud Gray	Black Glass	Pearl White	Cloud Gray
Net Volume (Liters)		45 L	87 L	87 L	87 L
Unit Dimension (mm) (WxDxH)		472 x 445 x 492	472 x 505 x 850	470 x 492 x 837	470 x 492 x 837
Voltage/Cycle		230V / 60Hz	230V / 60Hz	230V / 60Hz	230V / 60Hz
Defrosting System		Manual	Manual	Manual	Manual

Actual design and location of accessories may vary depending on model.
Specifications and features are subject to change without prior notice.

2

HANDLING & INSTALLATION

When moving the ref, hold the base and lift carefully at an angle not more than 45 degrees.

Do not place the ref horizontally or upside down.

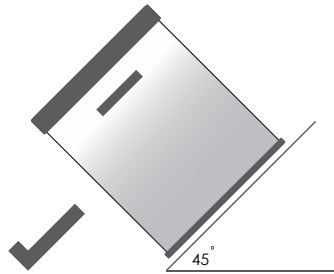

For proper ventilation, leave at least 12 inches of space between ref and ceiling or overhead pit; and 2 inches of space between ref and wall.

Place the refrigerator on a flat and firm ground for stability.

Keep the refrigerator in a well-ventilated area. Choose a location where there is no heat source like direct sunlight, oven, etc.

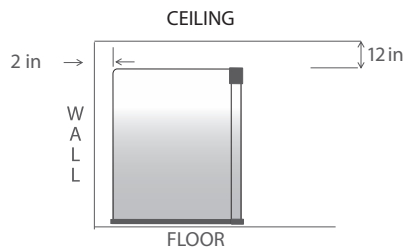

3

GETTING STARTED



Wait for **TWO HOURS BEFORE PLUGGING** your ref to make sure that motor oil has settled down. The temperature control knob should be in "OFF" position.

Plug the refrigerator directly to a 230V-wall outlet. Upon plugging, anticipate the humming sound of the compressor and check if the light inside the ref is turned on.

Do not use extension cord.



For CPR90TD Blk, CPR90TD Wht and CPR90TD CG, turn the control knob to "MAX" or coldest setting and allow to cool for 3 hours before loading food and beverage items.

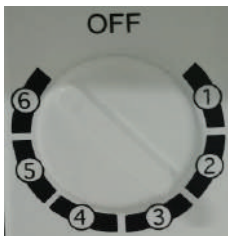

For CPR51MN CG. Turn the temperature control knob to "6" or coldest setting and allow to cool for 3 hours before loading food and beverage items.

4

TEMPERATURE CONTROL

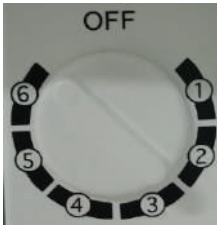

To adjust to desired temperature, turn the control knob clockwise or counter-clockwise.

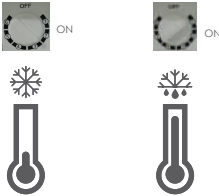

The "MAX" or "6" setting denotes the coldest temperature while the "MIN" or "1" setting denotes the warmest.

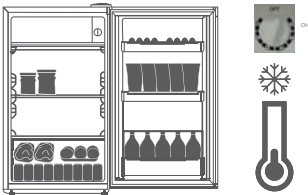

Adjust the temperature according to refrigerator load. For normal load, set the control knob at "3-4" or "MED" setting.

Recommended Temperature Setting

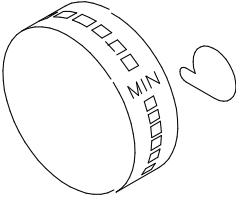
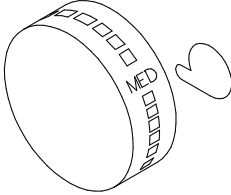
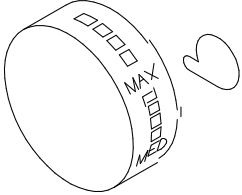
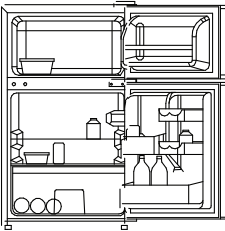
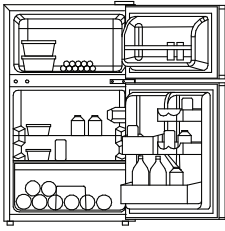
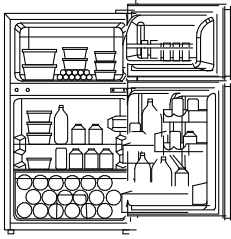
	MIN Setting	MID Setting	MAX Setting
	 <p>Set the control knob to MIN when storing MINIMUM amount of food and beverage items.</p>	 <p>Set the control knob to MED when storing MODERATE amount of food and beverage items.</p>	 <p>Set the control knob to MAX when storing LARGE amount of food and beverage items.</p>
CPR90TD Bk CPR90TD Wht CPR90TD CG			

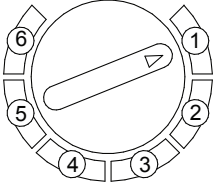
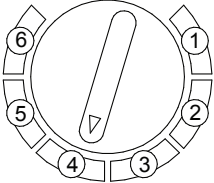
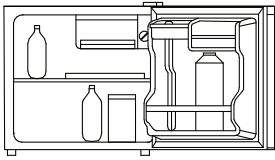
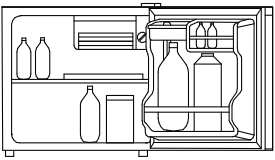
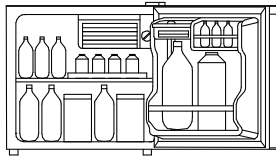
	Setting No. 1 to 2	Setting No. 3 to 4	
	<p data-bbox="288 469 333 491">OFF</p>  <p data-bbox="172 711 426 847">Set the control knob to no. 1 to 2 when storing MINIMUM amount of food and beverage items.</p>	<p data-bbox="598 469 642 491">OFF</p>  <p data-bbox="474 711 729 847">Set the control knob to no. 3 to 4 when storing MODERATE amount of food and beverage items.</p>	
<p data-bbox="109 903 138 1094" style="writing-mode: vertical-rl; transform: rotate(180deg);">CPR51MN CG</p>			

5

FOOD STORAGE



Cool down food to room temperature before putting it inside the ref.



Place food in airtight containers/ plastic.



DEFROSTING & CLEANING

When frost in freezer is already one-fourth inch(1/4") thick or more, it is time to DEFROST:

1. Turn OFF the temperature control knob then unplug the ref.
2. Remove all contents and detachable accessories.
3. After all the ice has melted, clean your ref with lukewarm water and mild soap. Wipe off using a soft, dry cloth.

USEFUL TIPS

- **When cleaning your refrigerator, do not use bleach, heavy detergent, or other abrasive cleaners.**
 - **Do not scrape ice using sharp and pointed metal tools to avoid damage and misuse, this voids warranty.**
 - **If you have to leave your ref unused for a long time, it is recommended that you leave your personal ref empty, clean and unplugged. Keep the door open to prevent growth of mold and mildew.**
-



SAFETY INSTRUCTIONS

A. POWER CORD

- Refrain from using an extension cord, octopus connection to prevent circuit overloading.
- The power cable tension must be a little loose when plugged.
- Keep the power cable away from the compressor.
- Do not attempt to replace or repair damaged power cord. Call customer hotline or any authorized service center immediately.
- When touching or cleaning the plug, make sure your hands and rug are dry.
- When unplugging, always grip the plug firmly and do not yank the power cord.
- Do not plug refrigerator in loose sockets.
- Ensure that the power cord is not bent excessively or pressed down by a heavy object.

B. STORAGE

- Do not store, use gasoline or any other flammable items near by the refrigerator.
- Storing hazardous materials, such as ether and benzyne, can cause an explosion.
- Do not store bottled drinks in the freezer.

C. HANDLING

- Never use flammable agents when cleaning the ref and its parts.
- Call customer care hotline or any authorized service center immediately if problem/s are encountered.
- Do not touch the freezer's inner wall with wet hands to avoid frost bite.
- Avoid water contact in areas near the temperature control knob to prevent shock hazards.
- Do not damage the refrigerant circuit.
- Do not place heavy item/s on top of the refrigerator.

D. DISPOSAL

Please contact local authorities for the proper disposal of your refrigerator. The gas in the insulation material requires special disposal procedure.

CAUTION or WARNING

- This appliance is not intended for use by persons (including children) with reduced physical, sensory or mental capabilities, or lack of experience and knowledge, unless they have been given supervision or instruction concerning use of the appliance by a person responsible for their safety.
 - In case of brownouts, wait at least five (5) minutes before turning the refrigerator's power up.
 - Do not use sharp objects or tools that may cause damage to the refrigerant circuit.
 - Do not use electrical appliances inside the food storage compartment.
 - The lamp must not be replaced by user! Call customer service hotline for replacement.
 - Keep ventilation openings, in the appliance enclosure or in the built-in structure, clear of obstruction.
-

8

BASIC TROUBLESHOOTING

PROBLEM	POSSIBLE CAUSE
1. When refrigerator would not turn ON:	<ol style="list-style-type: none">1. The power cord is not properly plugged.2. The temperature control knob is in "OFF" position.
2. When refrigerator is not cooling:	<ol style="list-style-type: none">1. The temperature control knob is not set according to refrigerator load.2. The refrigerator & freezer doors are not properly closed.3. The lamp remains on while the ref door is being closed.
3. When the refrigerator emits foul odor:	<ol style="list-style-type: none">1. There is spoiled food or drink inside the refrigerator.2. The refrigerator is not thoroughly cleaned after defrosting.
4. When there is dew or moisture in the vegetable compartment:	<ol style="list-style-type: none">1. The ref door is not tightly closed.2. The crisper pan is not pushed all the way back.
5. When there is sweating in the exterior ref cabinet during cold weather:	<ol style="list-style-type: none">1. The temperature control knob is not set according to refrigerator load.2. The refrigerator & freezer doors are not properly closed.
6. When refrigerator makes "unusual noise" like sizzling, ticking or humming:	<p>Please note that these may be normal sounds that indicate that your ref is working properly:</p> <p>"Sizzling" - This indicates that the refrigerant is passing through the freezer compartment</p> <p>"Ticking" - This indicates that the thermostat control is turning on and off.</p> <p>"Humming" - This is the sound of the motor, working.</p>

**CONCEPCION DURABLES INC
CUSTOMER SERVICE DEPARTMENT**

BUSINESS REPLY
PERMIT No. 2416A
NO STAMP NEEDED

Km. 20 East Service Road, Alabang, Muntinlupa

TRUNK LINE: #88635555

Mobile Nos.: 0947 996 2415 (Smart) "SMS Only"

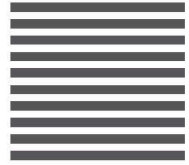

CUSTOMER SERVICE DEPARTMENT

GMA & LUZON AREA:

Address: Km. 20 East Service Road, Alabang, Muntinlupa

Trunk Line: #88635555

Mobile Number: +63 947 996 2415 (Smart) "SMS Only"

Covered Region/Areas: National Capital Region (NCR), Ilocos Region (Region I), Cordillera Administrative Region (CAR), Central Luzon (Region III), CALABARZON (Region IV-A), MIMAROPA Except Romblon, Bicol

Email Address: customercare@condura.com

CEBU Regional Office:

Address: Esperanza Bldg., AC Cortes St., Ibabao, Mandaue City Cebu

Landline: 32 328 1416

Mobile Number: '+63 947 996 2416 and '+63 999 887 1657

Covered Region/Area: Masbate, Central Visayas (Region VII), Eastern Visayas (Region VIII)

ILOILO Regional Office:

Address: 277 Iznart St., Brgy Danao, City Proper, Iloilo City

Landline: 33 336 1121

Mobile Number: +63 947 996 2417 and '+63 919 072 6530

Covered Region/Areas: Romblon, Western Visayas (Region VI)

CAGAYAN DE ORO Regional Office:

Address: 102 CKY Center, Capistrano St. corner Chaves St., Cagayan de Oro City

Landline: 88 881 0615

Mobile Number: +63 998 965 6756

Covered Region/Areas: Zamboanga Peninsula (Region IX), Northern Mindanao (Region X), Autonomous Region in Muslim Mindanao (ARMM) except Maguindanao, Agusan del Norte, Surigao del Norte

DAVAO Regional Office:

Address: 1C Nand Saling Bldg., Sobrecary St., Obrero, Davao City

Landline: 082 291 7276

Mobile Number: +63 998 965 6755

Covered Region/Area: Davao Region (Region XI), SOCCSKSARGEN (Region XII), Agusan del Sur, Surigao del Sur, Maguindanao

*All contact information detailed above may change without prior notice.

Fill-up this warranty card completely and mail within 15 days from date of purchase. This will activate your warranty from Condura!

CONDURA

MODEL NO.: _____ SERIAL NO.: _____
DEALER: _____ BRANCH: _____
DATE OF PURCHASE: _____ DEALER INVOICE NO.: _____
CUSTOMER NAME: _____ EMAIL ADDRESS: _____
ADDRESS: _____
TELEPHONE NO.: _____ MOBILE NO.: _____

I consent to the collection, processing and use by Concepcion Durables, Inc. (CDI) of the data above for the purposes identified in its Data Privacy Notice published in its website (www.condura.com), which is deemed incorporated into this Warranty Card.



CONDURA

PRODUCT WARRANTY CERTIFICATE

IMPORTANT: PLEASE READ CAREFULLY

Concepcion Durables, Inc. (CDI) warrants the purchaser, that this CONDURA refrigerator will be free from defective material and workmanship, and agrees to repair, or at its discretion, replace any defective material with a new or equivalent part, through any of its Authorized Service Centers, only if found to be manufacturer's defect and in accordance with the terms of this warranty, subject to the following conditions:

1. WARRANTY PERIOD (from the date of original purchase)

CONDURA		WARRANTY
1 year	-----	SYSTEM PARTS & LABOR (Refrigerant, Filter Drier, Motor Relay, & Freezer Coil), Lamp
5 years	-----	COMPRESSOR (Motor only. Does NOT include System Parts & Labor
NO Warranty	-----	Glass Shelves, Crisper Glass cover, Power Cord, Plastic Parts (bottle racks, crisper pan, rubber gasket)

There will be corresponding charges for labor and replacement parts after the warranty period.

2. COVERAGE OF WARRANTY

The CONDURA warranty is also applied to refrigerators used for **household purpose only**

3. LIMITATIONS

This warranty is not transferable, valid only in the Philippines, and does not apply to damage(s) due to fire, improper use or abuse (punctured), force majeure (typhoon, flood, lightning, earthquake, etc.), use with voltages beyond the allowable range of 198V to 242V, or failure to follow operating instructions, provided in the manual, if the serial number is removed or defaced, or if the unit has been tampered with, altered or in any way repaired, serviced or worked on by anyone other than a duly authorized representative or Service Center, this warranty is considered null and void. Concepcion Durables, Inc. (CDI) offers this warranty as the only remedy available to the original purchaser for any defect, that may arise within the warranty period. Correction of defects shall be considered as complete fulfillment of liabilities and responsibilities of CDI to the original purchaser. In no event shall CDI be held liable for any damage or consequence that may arise as a result of using this CONDURA product.

MODEL NUMBER: _____ SERIAL NUMBER: _____

NOTE: Keep this warranty card together with your Original Sales Invoice / Official Receipt as proof of purchase. If the date of purchase cannot be proven, warranty shall be based on CDI's invoice to Dealer.



CONCEPCION DURABLES INCORPORATED

www.facebook.com/ConduraPhilippines

www.condura.com

CONDURA

www.condura.com